

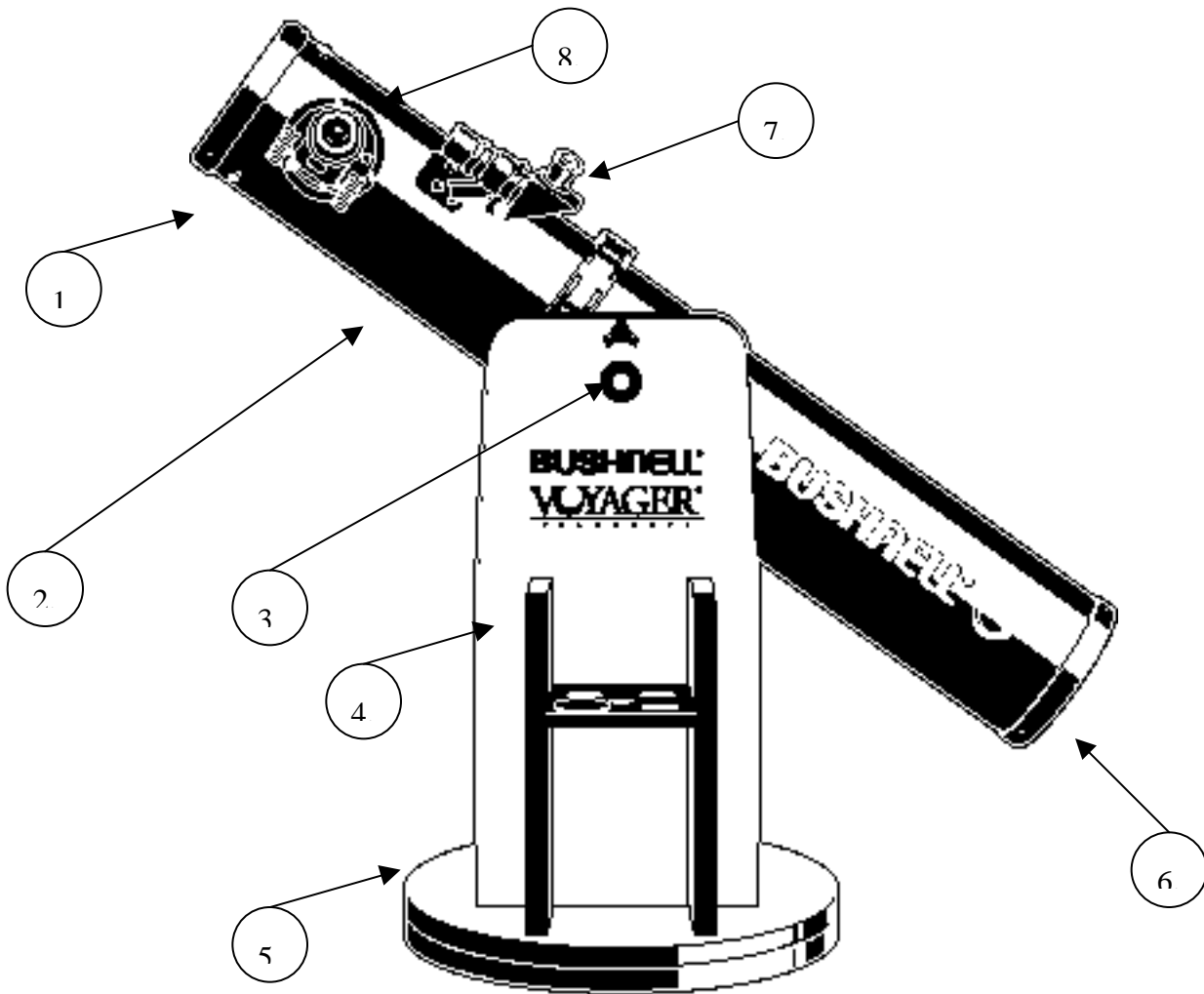

**VOYAGER® 4.5 INCH DOBSONIAN TELESCOPE
MODEL 78-4500**



- | | |
|----------------------------------|-------------------------------------|
| 1. Rack & Pinion Focusing System | 5. Dobsonian Base (Azimuth Bearing) |
| 2. Reflector Body | 6. Primary Mirror |
| 3. Altitude Bearing | 7. Finderscope |
| 4. Dobsonian Side Panel | 8. 1.25" Format Eyepiece |

*Never Look Directly At The Sun With Your Telescope
Permanent Damage To Your Eyes May Occur*

Thank you for purchasing the Bushnell Voyager Dobsonian Telescope! Your new telescope has been designed and crafted with the highest standards so that you may have years of enjoyment and use out of this wonderful window to the heavens. This product comes complete with everything you'll need to explore your universe including a professional primary mirror, precision rack and pinion focusing mechanism, superior all-metal main telescope tube, and professional quality wide-field 5x24mm finderscope. Whether you are just starting out in astronomy or you are an avid astronomer we wish you all the best with your telescope.

Please utilize this manual to its fullest potential by reading it completely before you attempt to assemble and use your new telescope. Once assembled, we've included a basic guide on how to get started in astronomy at the end of this manual. While this is not a complete guide, it will give you some initial pointers. As you advance in ability, we would highly recommend a supplemental star atlas, beginning astronomy guide, moon map, or any other guide as you travel on your journey through the universe.

READ THROUGH ASSEMBLY INSTRUCTION BEFORE YOU ASSEMBLE YOUR TELESCOPE

TELESCOPE ASSEMBLY INSTRUCTIONS

Your Bushnell Voyager Dobsonian Telescope comes **preassembled** from the factory. By simply attaching the accessory finderscope and eyepiece, you will be ready to explore.

ATTACH FINDERSCOPE

1. Remove Reflector Telescope Assembly (2) and Finderscope (7) from carton.
2. Remove nuts located near the Rack & Pinion Focusing Mechanism (1) on Reflector Telescope Body (2).
3. Attach Finderscope (7) to Reflector Telescope Body (2) by inserting the bolts extending from the Reflector Telescope Body (2) into the holes in the base of the Finderscope (7).
4. Refasten nuts so that Finderscope (7) is secure.

THE FINAL STEPS

1. Remove 1.25" Format Eyepiece (8) from carton.
2. Insert into Rack & Pinion Focusing Mechanism (1).
3. Remove Protective Dust Cover from end of telescope nearest the Rack & Pinion Focusing Mechanism (1).
4. Let the adventure begin.

Your Bushnell Telescope is now ready to be used. To obtain the fullest enjoyment from your telescope, please refer to the following additional information.

Astronomical Telescopes are designed in such a way that the image you will see appear will be UPSIDE DOWN and REVERSED, this is acceptable for viewing celestial bodies.

TELESCOPE USE

SELECTING AN EYEPIECE:

1. You should always start viewing with the lowest power eyepiece, which in this case is the 20 mm lens. Note: the base power of each eyepiece is determined by the focal length of the telescope objective element, which for this model is 900 mm. A formula can be used to determine the power of each eyepiece: **telescope OBJECTIVE mirror focal length ÷ EYEPIECE focal length = MAGNIFICATION** (e.g. Using the 20 mm lens, the calculation would look like this: $900 \text{ mm} \div 20 \text{ mm} = 45\text{x}$ or 45 power.)
2. Included with this telescope is a Barlow lens. Barlow lenses are used to double or triple the power of your telescope. Place your Barlow between the focusing tube and the eyepiece. Using the example above, your 3x Barlow lens would give you a total power of 81x or 81 power. ($27 \times 3 = 81\text{x}$ or 81 power)
3. Other accessories available include a 9mm eyepiece (model #78-0101) and a standard camera adapter (model #78-0104) for photographing the night sky.

FOCUSING TELESCOPE:

1. After inserting the eyepiece, aim the main telescope tube at a land-based target at least 200 yards away (e.g. A telephone pole or building). Fully extend focusing tube by turning Rack & Pinion Focusing Mechanism (1)
2. While looking through selected eyepiece (in this case the 20 mm), slowly retract focusing tube by turning Rack & Pinion Focusing Mechanism (1) until object comes into focus.

ALIGNING FINDERSCOPE:

1. Look through low-power 1.25" format eyepiece (8) and establish a well-defined target (see focusing telescope section).
2. Looking through Finderscope (7), alternate tightening each Finderscope Adjustment Screw surrounding the Finderscope (7) in the Finderscope Mount until crosshairs of Finderscope (7) are precisely centered on the same object already centered in Main Telescope Tube's field of view as seen through the 1.25" Format Eyepiece (8).
3. Now, objects located first with the Finderscope (7) will be centered in the field of view of the main telescope as seen through the 1.25" Format Eyepiece (8).

Enjoying Your New Telescope

1. First determine your targeted object. Any bright object in the night sky is a good starting point. One of the favorite starting points in astronomy is the moon. This is an object sure to please any budding astronomer or experienced veteran. When you have developed proficiency at this level, other objects become good targets. Saturn, Mars, Jupiter, and Venus are good second steps to take.
2. The first thing you need to do after assembling the telescope as planned is center the desired object in the finderscope's cross hairs. Provided you did a reasonable job aligning the finderscope, a quick look through the main telescope tube at low power should reveal the same image. With the lowest power eyepiece (the one with the largest number printed on it) you should be able to focus the same image that you saw through the finderscope. Avoid the temptation to move directly to the highest power. The low power eyepiece will give you a wider field of view, and brighter image--thus making it very easy to find your target object.

At this point with a focused image in both scopes, you've passed the first obstacle. If you don't see an image after attempting to focus it in, you might consider aligning your finderscope again. Once you pass this step, you'll will enjoy the time spent ensuring a good alignment. Every object you center in the finderscope will be easily found in the main telescope tube, which is important for continuing your exploration of the night sky.

3. The low power eyepieces are perfect for viewing the full moon, planets, star clusters, nebulae, and even constellations. These should build your foundation. However, for more detail, try bumping up in magnification to higher power eyepieces on some of these objects. During calm and crisp nights, the light/dark separation line on the moon (called the "Terminator") is marvelous at high power. You can see mountains, ridges and craters jump out at you due to the highlights. Similarly, you can move up to higher magnifications on the planets and nebulae. Star clusters and stars are best viewed through the low power no matter what.
4. The recurring astronomical theater we call the night sky is an ever-changing billboard. In other words, not the same movie plays all the time. Rather, the positions of the stars change not only hourly as they seem to rise and set, but also throughout the year. As the earth orbits the sun our perspective on the stars changes on a yearly cycle about that orbit. The reason the sky seems to move daily just as the sun and the moon "move" across our sky, is that the earth is rotating about its axis. As a result you may notice that after a few minutes or a few seconds depending on what power you are viewing at, the objects in your telescope will move. At higher magnifications especially, you will notice that the moon or Jupiter will "race" right out of the field of view. To compensate, just move the fine adjustment controls on your telescope to "track" it in the necessary path.

Helpful Hints

1. Your telescope is a very sensitive instrument. For best results and fewer vibrations set your telescope up on a level location on the ground rather than your concrete driveway or your wooden deck. This will provide a more stable foundation for viewing, especially if you've drawn a crowd with your new telescope.
2. If possible view from a location that has relatively few lights. This will allow you to see much fainter objects. You'd be surprised how much more you'll see from your local lake or park when compared to a backyard in the city.
3. Using your telescope out a window is NEVER recommended.
4. View objects that are high in the sky if possible. Waiting until the object rises well above the horizon will provide a brighter and crisper image. Objects on the horizon are viewed through several layers of earth's atmosphere. Ever wonder why the moon appears orange as it sets on the horizon. It's because you are looking through a considerable more amount of atmosphere than you would directly overhead. (Note: If objects high in the sky are distorted or wavy, you are probably viewing on a very humid night.) During nights of unstable atmosphere, viewing through a telescope can be frustrating if not impossible. Astronomers refer to crisp, clear nights as nights of "good seeing."

Where do I start?

Your Bushnell telescope can bring the wonders of the universe to your eye. While this manual is intended to assist you in the set-up and basic use of this instrument, it does not cover everything you might like to know about astronomy. The first thing you need to do is get a very simple star chart and a flashlight with a red bulb or red cellophane over the end. For objects other than stars and constellations, a basic guide to astronomy is a must. Some recommended sources appear on our website at www.bushnell.com. Also on our website will be current events in the sky for suggested viewing. But, some of the standbys that you can see are:

The Moon--a wonderful view of our lunar neighbor can be enjoyed with any magnification. Try viewing at different phases of the moon. Lunar highlands, lunar maria (lowlands called "seas" for their dark coloration), craters, ridges and mountains will astound you.

Saturn--even at the lowest power you should be able to see Saturn's rings and moons. This is one of the most satisfying objects in the sky to see simply because it looks like it does in pictures. Imagine seeing what you've seen in textbooks or NASA images from your backyard!

Jupiter--the largest planet in our solar system is spectacular. Most noted features are its dark stripes or bands both above and below its equator. These are the north and south equatorial belts. Also interesting are Jupiter's four major moons. Pay close attention to their positions from night to night. They appear to be lined up on either side of Jupiter.

Mars--The Great Red Planet appears as a reddish-orange disk. Look at different times of the year and try to catch a glimpse of the white polar ice caps.

Venus--just like the moon, Venus changed phases from month to month. Some views of brilliant Venus appear as if you were looking at a distant crescent moon.

Nebulae--The Great Orion Nebula is a very well known night sky object. This and many others are brought to you by this telescope.

Star Clusters--View millions of stars densely packed in a cluster that resembles a ball.

Galaxies--One of the greatest and most interesting galaxies is our neighbor the Andromeda Galaxy. Enjoy this and many others. Much, much, more!

www.bushnell.com

ANSWERS TO COMMONLY ASKED QUESTIONS

1. The image I see in the telescope is upside down and reversed from right to left ?	• An upside-down and reversed image is a common characteristic of most astronomical telescopes. Since telescopes are used for astronomical viewing orientation is not important. The image in the finderscope will also be reversed.
2. How do I determine the power my telescope ?	• The power of your telescope can be determine by dividing the focal length of the objective lens by the focal length of the eyepiece. The eyepiece focal

	length is the number printed on the eyepiece. (For example: $900 \div 20 = 45X$)
3. Where do I find the Telescope Focal Length	<ul style="list-style-type: none"> The telescope focal length is the same focal length as the objective focal length. For this telescope it is 900mm. Telescope focal lengths range from 600mm to 1200mm on Bausch & Lomb and Bushnell telescopes.
4. What can I see with my telescope ?	<ul style="list-style-type: none"> Telescopes with power ranging from 25X to 50X can be used to view Star Clusters and Nebulae. 90X to 120X telescope can view galaxies. Most planets can be seen at any magnification.
5. What do the numbers on the eyepiece mean ?	<ul style="list-style-type: none"> The numbers on the eyepiece represents the “focal Length” of the eyepiece.

TROUBLESHOOTING GUIDE

<i>If after you have set-up your new telescope you are unable to see any objects, use this Quick Reference guide to help you to understand the cause of the problem and quickly determine a remedy</i>	
1. I've completed the set-up yet I cannot see anything	<ul style="list-style-type: none"> Check to see if objective lens cover and all other lens covers have been removed.
	<ul style="list-style-type: none"> Try to view an object that is 200 or more yards away.
	<ul style="list-style-type: none"> If there is more than one eyepiece included with the telescope, use the lowest power (highest number) eyepiece to begin viewing.
	<ul style="list-style-type: none"> Use the Rack & Pinion Focusing Mechanism to bring the object you are trying to view into focus

Telescope LIFETIME LIMITED WARRANTY

Your telescope is warranted to be free of defects in materials and workmanship for the lifetime of the original owner. The Lifetime Limited Warranty is an expression of our confidence in the materials and mechanical workmanship of our products and is your assurance of a lifetime of dependable service.

If your telescope contains electrical components the electronic components are warranted to be free of defects in materials and workmanship for one year after the date of purchase.

In the event of a defect under this warranty, we will, at our option, repair or replace the product, provided that you return the product postage prepaid. This warranty does not cover damages caused by misuse or improper handling, installation or maintenance of the product. Any return made under this warranty must be accompanied by the items listed below:

- 1) A check in the amount of \$15.00 to cover the cost of handling
- 2) Name and address for product return
- 3) An explanation of the defect
- 4) Product should be well packed in a sturdy outside shipping carton to prevent damage in transit and return postage prepaid to the address listed below:

IN U.S.A. Send To:

Bushnell * 8500 Marshall Drive * Lenexa, Kansas 66214

IN CANADA Send To:

Bushnell * 25A East Pearce Street, Unit 1 * Richmond Hill, Ontario L4B 2M9

For products purchased outside the United States and Canada please contact your local dealer for applicable warranty information. This warranty gives you specific legal rights. You may have other rights which vary from country to country.

©2001 Bushnell Performance Optics